

Wave Parameters and Behaviours

Longitudinal and transverse waves

- Waves provide a way of transferring energy. Give two examples of waves and state the energy they transfer.
- Look at the two diagrams below. State which represents a longitudinal wave and which a transverse wave.

Wave A

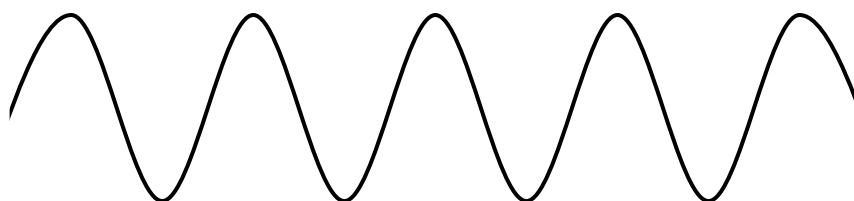

Wave B

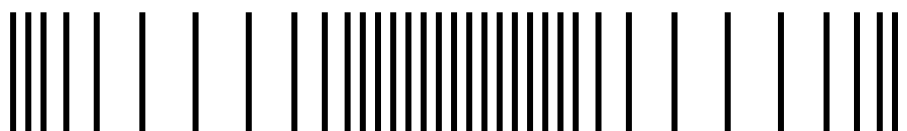

- Describe how you could use a 'Slinky' spring to demonstrate:
 - a transverse wave
 - a longitudinal wave.
- State which of the waves below are longitudinal waves and which are transverse waves

water waves light sound radio waves x-rays

Wave speed, frequency, wavelength, period and amplitude

- Copy and complete the table to define some properties of waves.

Property	Symbol	Unit	Definition
Amplitude	none	m	(a)
(b)	λ	m	The horizontal distance between the point on a wave and the identical point on the next wave.
Frequency	f	(c)	The number of waves per second.
Period	T	(d)	The time it takes for one wave to pass a point.
Speed	v	m s ⁻¹	(e)

6. State an equation that links frequency and the period of a wave.
7. Calculate the period of waves which have a frequency of 10 hertz.
8. What is the period of water waves with a frequency of 0.25 hertz?
9. Waves have a period of 0.2 seconds. Calculate their frequency.
10. Waves have a period of 0.01 seconds. Calculate their frequency.

11. Ripples are produced on a ripple tank like the one shown opposite. Calculate the frequency when:

- (a) 10 waves pass a point in 2 s;
- (b) 18 waves pass a point in 6 s;
- (c) 4 waves pass a point in 4 s;
- (d) 100 waves pass a point in 20 s;
- (e) 5 waves pass a point in 10 s.

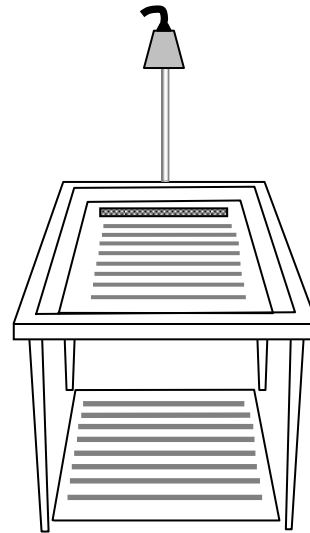

12. Look at the diagrams of waves below. From the information provided, find the frequency of the waves.

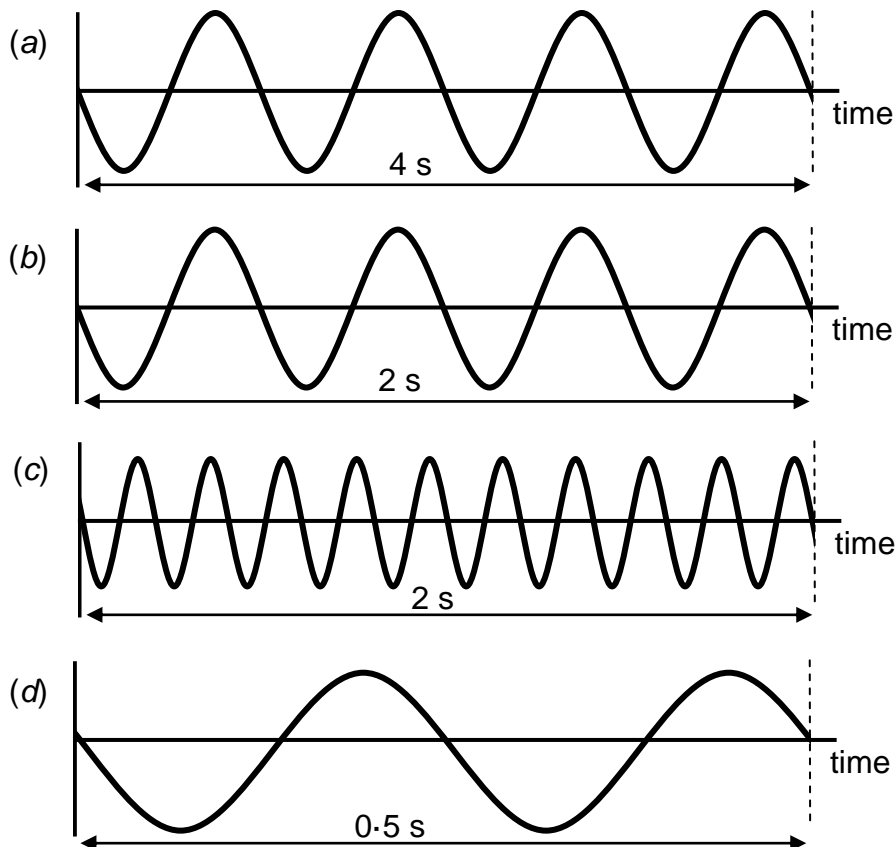

13. Use the information provided on the diagrams below to find the amplitude of each wave.

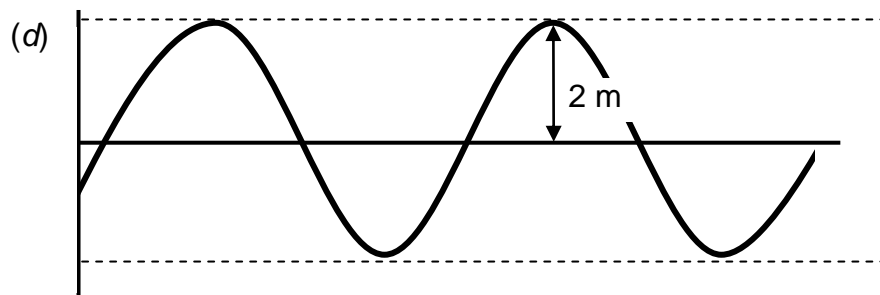
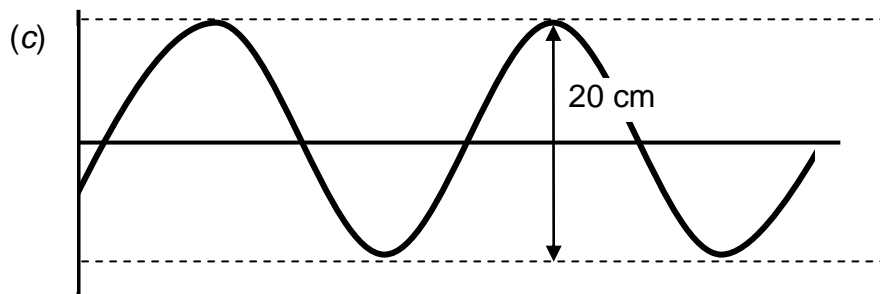
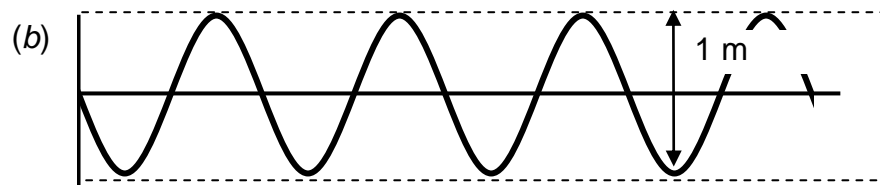
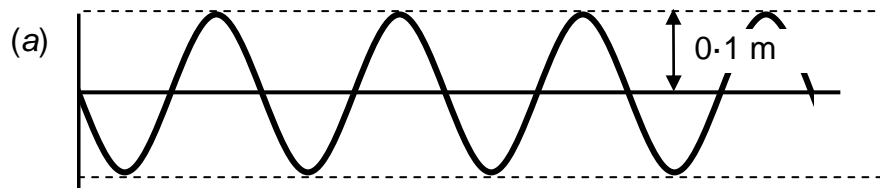

14. A loudspeaker vibrates at a frequency of 256 Hz to produce the note we call "middle C"

- (a) How many waves does it produce in one second?
- (b) How many waves does it produce in one minute?

15. Longitudinal waves are sent along a slinky spring. Four waves pass a point in 2 s. What is the frequency of the waves.

16. An alarm on a phone produces a tone with a frequency of 500 Hz. How many waves will be produced in:

- (a) 1 s;
- (b) 5 s;
- (c) 0.1 s?

Calculating wave speed using frequency and wavelength

17. State an equation that links wave speed, frequency and wavelength.

18. Calculate the missing values in the table below.

<i>Wave speed</i>	<i>Frequency</i>	<i>Wavelength</i>
(a)	10 Hz	2 m
(b)	0.5 Hz	10 m
4 m s ⁻¹	2 Hz	(c)
50 m s ⁻¹	10 Hz	(d)
340 m s ⁻¹	(e)	5 m
2 m s ⁻¹	(f)	10 m
3 × 10 ⁸ m s ⁻¹	200 kHz	(g)
3 × 10 ⁸ m s ⁻¹	(h)	100 m
(i)	6.0 × 10 ¹⁴ Hz	500 × 10 ⁻⁹ m

19. A frequency meter is used in a laboratory to measure frequency. When used to find the highest frequency a student can hear it displays 17 000 Hz. Calculate the wavelength of the sound wave if sound travels at 340 m s⁻¹.

20. A note played on a piano has a wavelength of 0.25 m. Calculate its frequency if sound waves travel at 340 m s⁻¹.

21. Water waves travelling along a canal have a wavelength of 2.0 m and a frequency of 0.5 Hz. Calculate their speed.

22. A speedboat produces waves with a frequency of 2.0 Hz and a wavelength of 3.0 m. Calculate the speed of the waves.

23. Calculate the wavelength of each of the following radio stations broadcast in Aberdeen. Radio waves travel at $3 \times 10^8 \text{ m s}^{-1}$.

- (a) FM Radio Scotland - 93.1 MHz
- (b) FM Northsound One - 96.9 MHz
- (c) FM Original - 106.8 MHz
- (d) MW Absolute Radio - 1215 kHz
- (e) LW BBC Radio 4 - 198 kHz

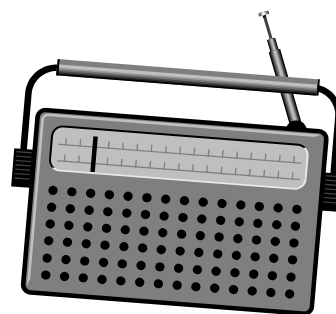

24. Red light has a wavelength of 700 nanometres or $700 \times 10^{-9} \text{ m}$. Calculate the frequency of red light if it travels at a speed of $3 \times 10^8 \text{ m s}^{-1}$.

Calculating wave speed using distance and time

25. State an equation that links wave speed, distance and time.

26. Calculate the missing values in the table below.

<i>Speed</i>	<i>Distance</i>	<i>Time</i>
(a)	40 m	5 s
(b)	4 m	0.2 s
340 m s^{-1}	1700 m	(c)
5 m s^{-1}	2 km	(d)
340 m s^{-1}	(e)	8 s
2 m s^{-1}	(f)	10 s

27. A wave travels at 1.5 m s^{-1} . Calculate the time it will take to travel 30 m.

28. Very high waves produced in the ocean due to earthquakes are called tsunamis. A tsunami travelled from Sumatra to Somalia, a distance of 6000 km, in 7 hours. Calculate the speed of this wave in metres per second.

29. How long would it take a sound wave to travel from one end of a football pitch to the other if it is 105 m long? (Speed of sound in air is 340 m s^{-1}).

30. A surfer rides along the crest of a wave for a distance of 48 m in 12 s. Calculate their speed.



31. Light travels through space at 3×10^8 m s⁻¹.

(a) The moon is 3.8×10^8 m from Earth. Calculate the time it will take for light reflected from the moon to reach Earth.

(b) The Sun is an average of 1.5×10^{11} m from the Earth. Calculate the time it will take for light from the Sun to reach Earth.

Diffraction of waves

32. The pattern shown opposite is seen on a ripple tank.

What name is given to the effect of the barrier on the water waves?

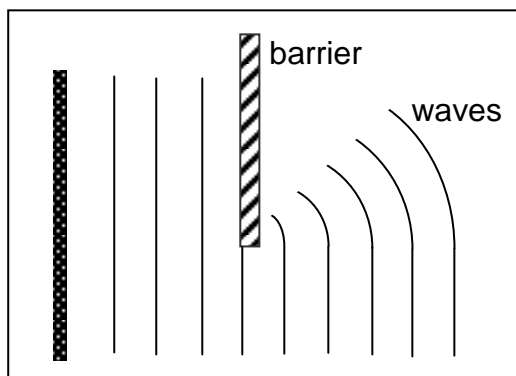

33. Copy and complete the diagram below for waves on a ripple tank to pass through a gap in a barrier.

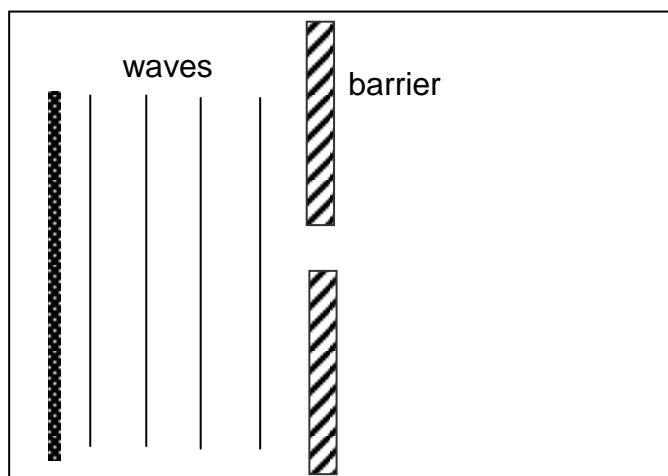

34. (a) What is the bending of waves called?

(b) Copy and complete the following sentence:

Waves which have a _____ wavelength bend more than waves which have a _____ wavelength.

Extension Questions

35. A pupil uses his mobile phone on the way home from school to call his friend. The receiver which picks up the signal from his mobile phone is 9 km from the pupil.



(a) Calculate the time it will take the radio wave to reach the receiver if the radio was travel at $3 \times 10^8 \text{ m s}^{-1}$.

(b) The radio wave is transmitted with a frequency of 1800 MHz. Calculate the wavelength of the **radio wave**.

36. Drivers often use remote controls to lock and unlock their car doors. The controller emits a radio wave which will operate the door locks.

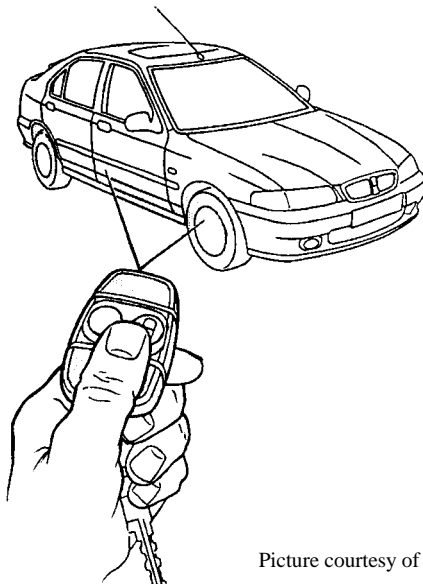

Picture courtesy of Rover Group Ltd.

(a) What is the speed of radio waves in air?

(b) The radio wave from the transmitter has a frequency of 433 MHz. Calculate the wavelength of the wave.

(c) If someone stands in front of the transmitter, the locks still operate. Discuss how diffraction may explain this including the effect of the wavelength on the radio wave.

37. Read the passage below about waves then answer the questions which follow.

If you stand at the corner of a building you cannot see your friend who may be just around the corner. You will be able to hear them if they speak though. Why is this? It is due to a phenomenon called diffraction. Waves have the ability to bend around objects. How much diffraction takes place depends upon the wavelength of the waves and the size of the object. Sound waves have a wavelength much greater than light so are able to bend around the wall whilst light waves cannot.

The bending of waves around objects can be useful but can also cause problems. Depending upon the wavelength of sounds, it is possible to get acoustic (sound) shadows in the same way as you can get light shadows. Special barriers, called bunds, can be built between busy roads and houses which could be mounds of earth or heavily built fences. They will reduce the noise of traffic but lower frequency 'rumbles' can still diffract over the top of these barriers.



Earth bund beside the M40

© Copyright [Robin Stott](#) and licensed for reuse under the [Creative Commons Licence](#)

TV signals and high frequency radio broadcasts have wavelengths of a few metres which means that the waves are unable to diffract around large buildings or hills. This can mean poor reception for those living behind the obstacle. Long wave (LW) radio however, has a wavelength of around a kilometre. This means that radio stations using long wave signals can be easily received where other stations cannot.

- (a) What name is given to the bending of waves around an obstacle?
- (b) Explain why it is possible to hear someone around the corner of a building even though you can't see them.
- (c) Why do sound barriers at the sides of roads not cut out all noise?
- (d) There is only a single transmitter for the whole of the UK for Radio 4 LW. Why must there be many local transmitters for Radio 4 broadcast on high frequency FM?

Light

Refraction of light

38. What angle does the normal make with the surface of a glass block?

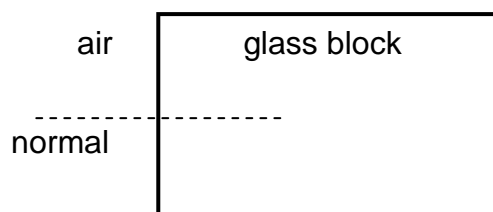

39. Copy and complete the following sentences using the words below.

decreases towards away from less than
greater than increases

- (a) When a light ray enters a glass block from air it refracts _____ the normal.
- (b) When a light ray leaves a glass block into air it refracts _____ the normal.
- (c) When light enters a glass block from air its speed _____ .
- (d) When light leaves a glass block and enters air its speed _____ .
- (e) When a ray of light travels from air into glass, the angle of refraction is _____ the angle of incidence.
- (f) When a ray of light travels from glass into air, the angle of refraction is _____ the angle of incidence.

40. Which of the angles in the diagram below (P, Q, R or S) represents:

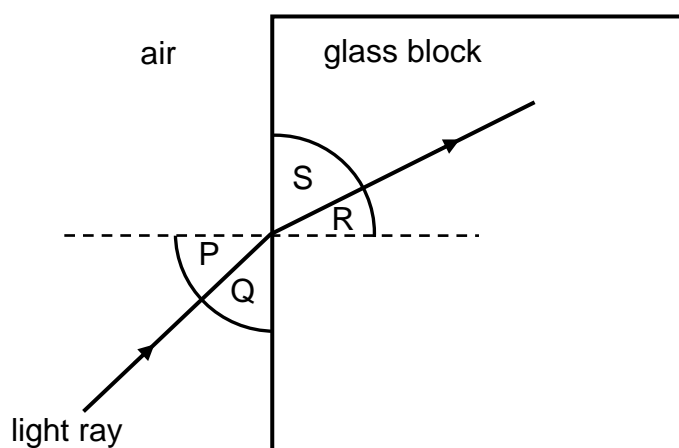

- (a) the angle of incidence;
- (b) the angle of refraction.

41. A ray of red light is shone into a number of glass blocks as shown below. State which correctly show the path of the ray of light.

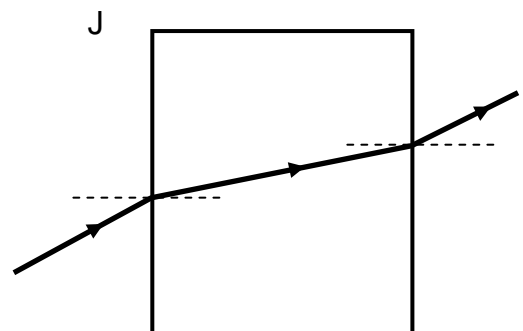
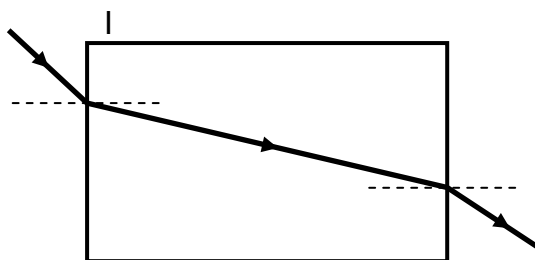
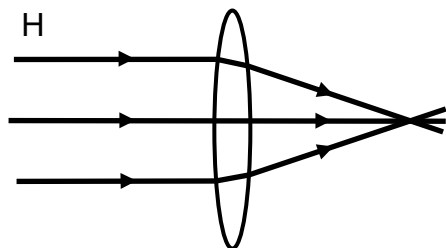
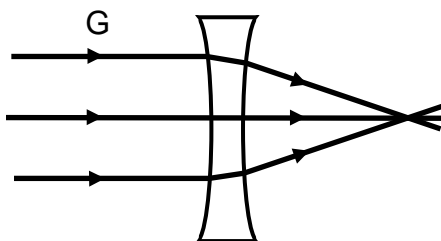
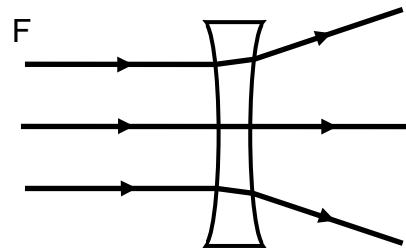
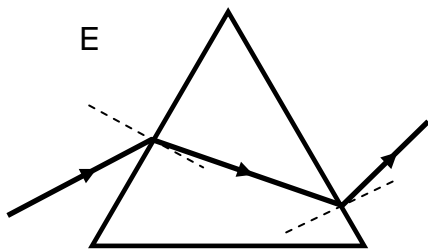
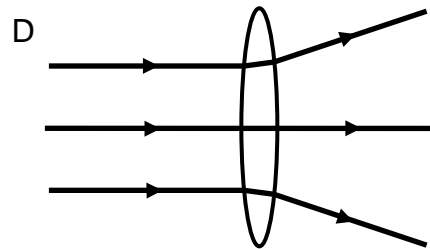
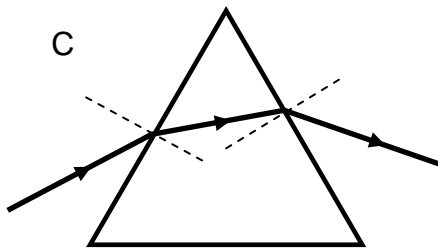
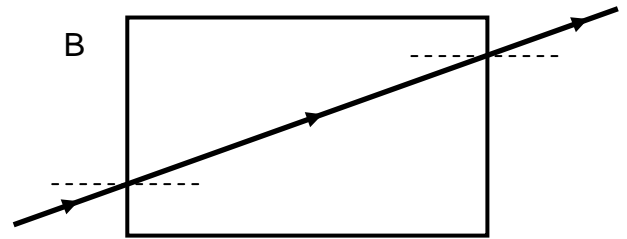
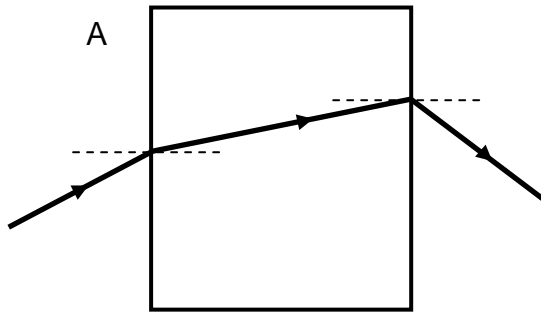

42. Identify the angle of incidence and the angle of refraction in the following examples.

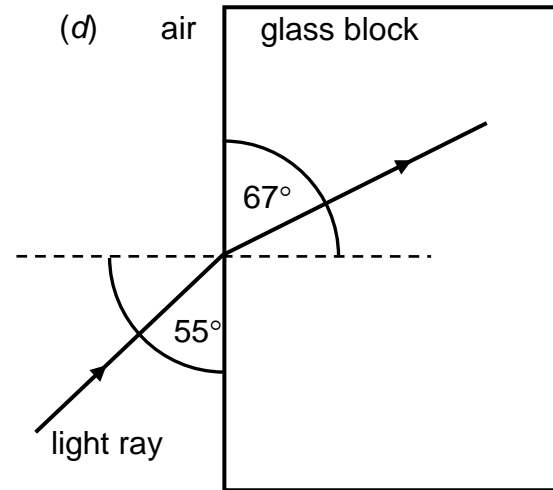
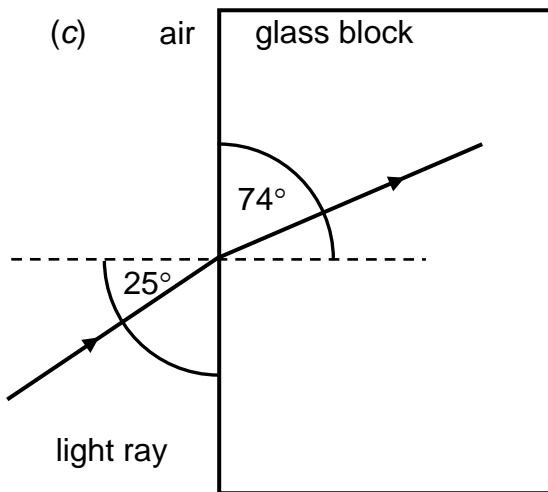
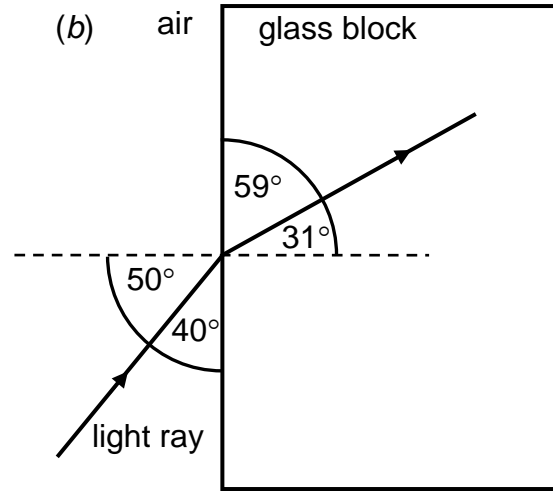
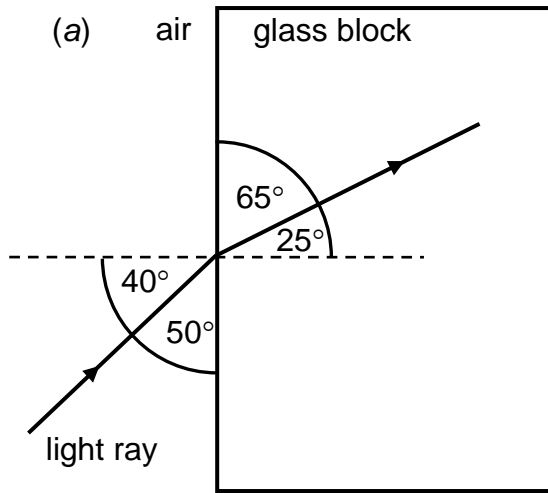

43. An optician prescribes a pair of glasses for a patient who is short sighted.

(a) Copy the diagram below and complete the rays to show how the patient has blurred vision when viewing a distant object

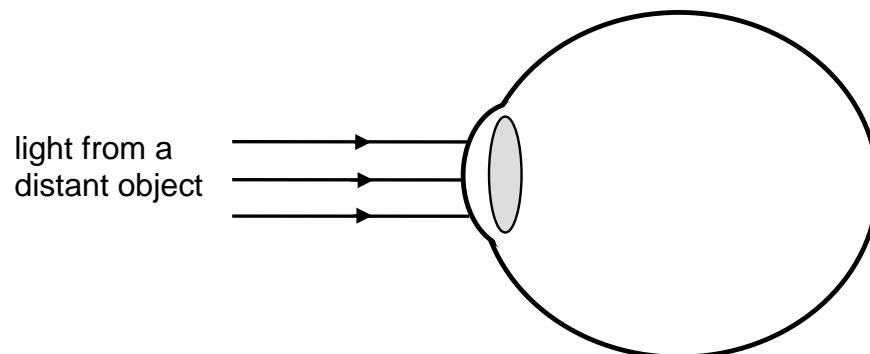

(b) State the shape of lens required in the patients glasses to correct this vision defect.

44. An optician prescribes a pair of glasses for a patient who is long sighted.

(a) Copy the diagram below and complete the rays to show how the patient has blurred vision when viewing a nearby object

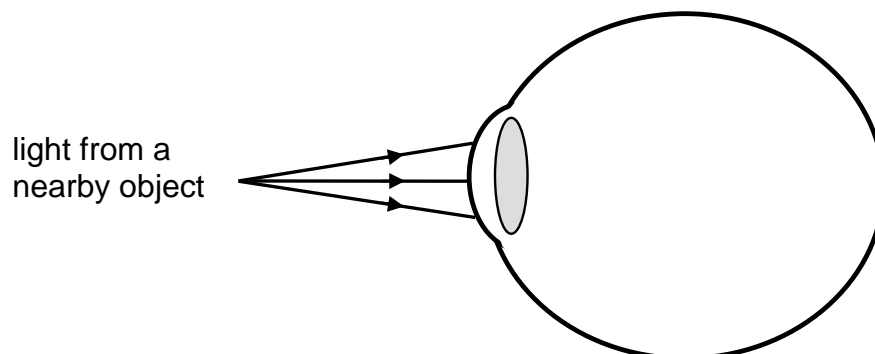

(b) State the shape of lens required in the patients glasses to correct this vision defect.

45. Explain what is meant by total internal reflection, saying when it will occur.

46. Rays of light are shone into a semi-circular glass block like the one shown opposite.

The angle θ represents the critical angle for the glass block. Describe what would be seen if a ray of light were shone in towards the centre of the block:

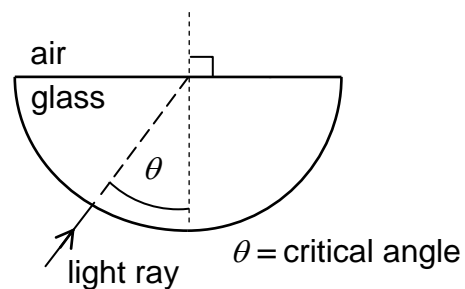

- (a) at an angle below the critical angle;
- (b) at the critical angle;
- (c) at an angle above the critical angle.

47. An optical fibre uses total internal reflection to transmit light along its length. Copy and complete the sketch below to show this.

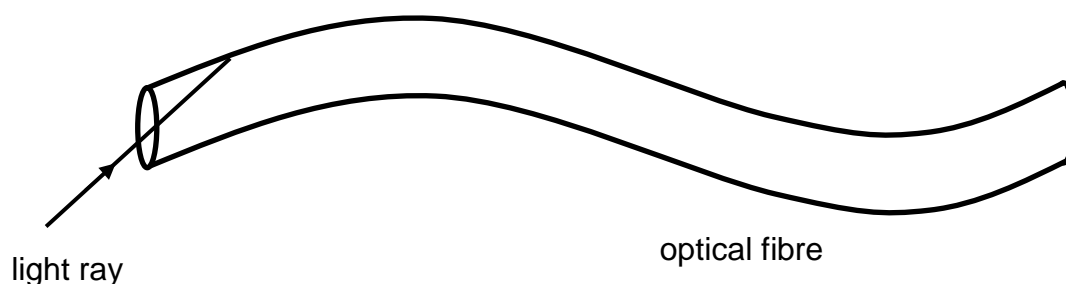

Extension Questions

48. Light enters a glass block shown below. Use your knowledge of refraction and geometry to calculate the angles the light makes till it escapes from the block.

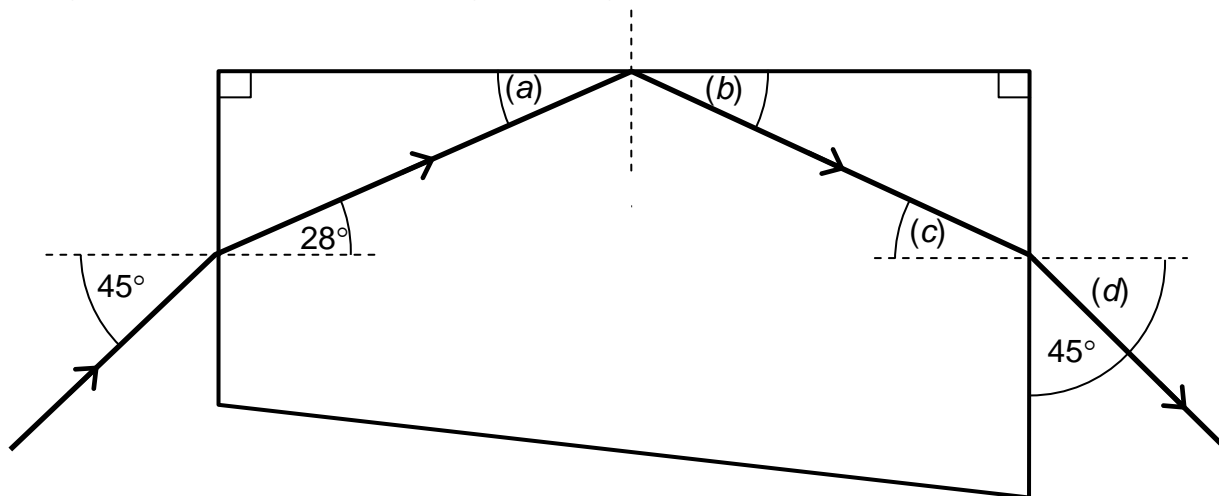

49. Some modern cars have automatic windscreen wipers which are activated when it rains. The heavier the rain the more frequently they operate. A sensor placed on the inside of the windscreen directs a beam of light towards the windscreen at the critical angle for glass to air. The light is reflected back into a sensor which measures the light intensity. When it rains, the droplets of water on the glass causes some light to be refracted out rather than reflected.

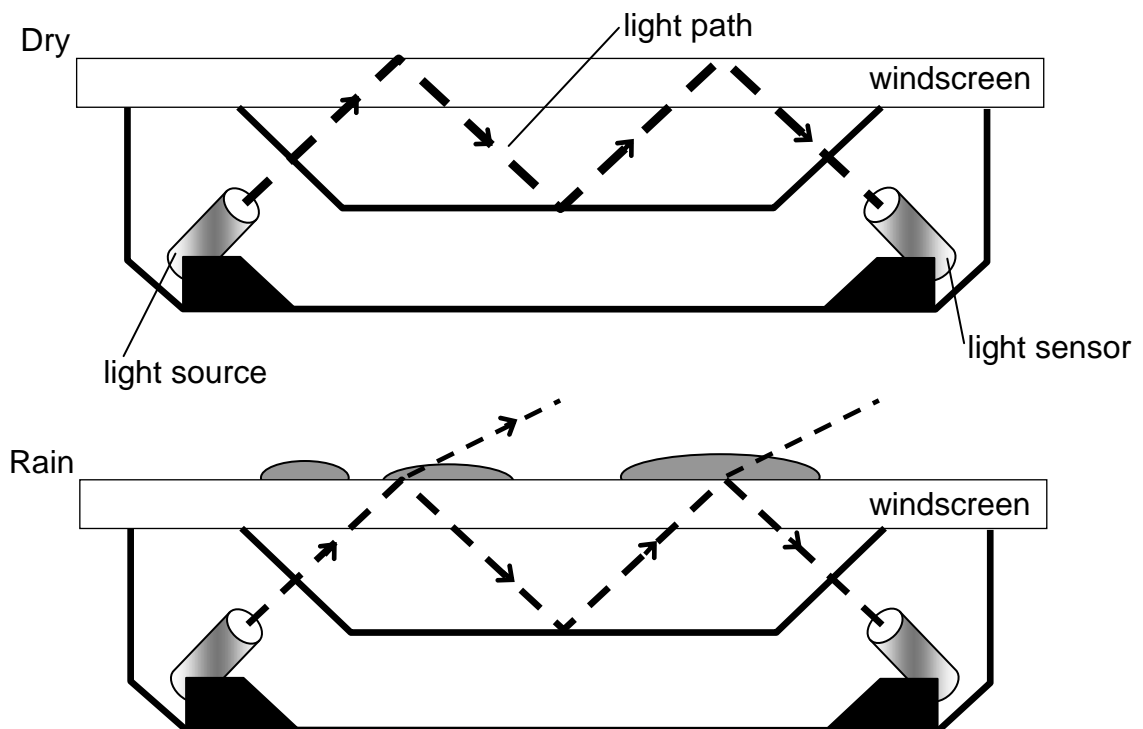

- (a) What name is given to the effect when light is reflected from the windscreen in dry conditions?
- (b) How will the light intensity falling on the sensor change as the amount of rain increases? Give reasons for your answer.

50. Light from a lamp is shone through two lenses onto a screen as shown below.

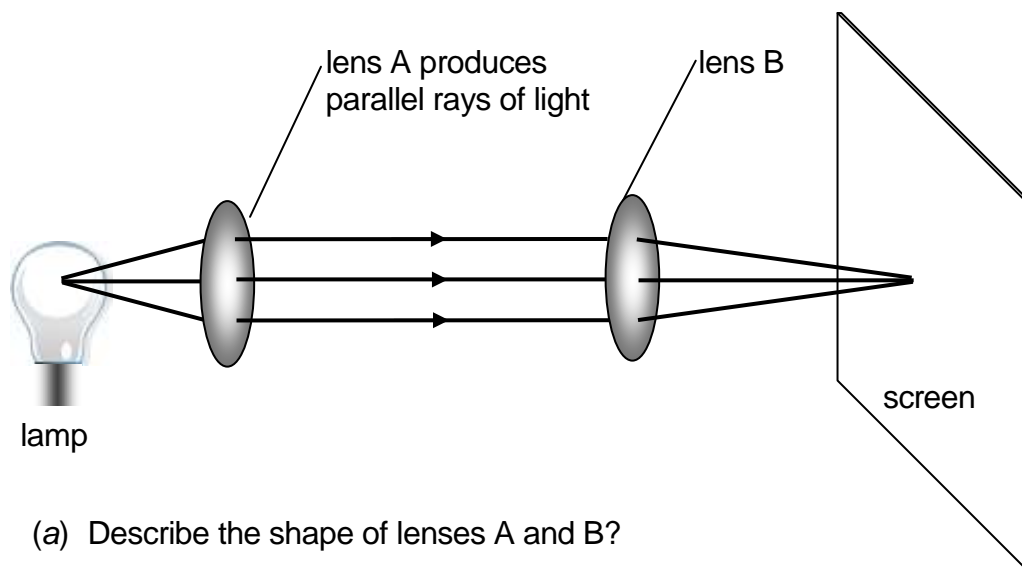

- (a) Describe the shape of lenses A and B?
- (b) Lens A is now moved so that the rays emerging from it are travelling as shown below. As a result the image on the screen becomes blurred.

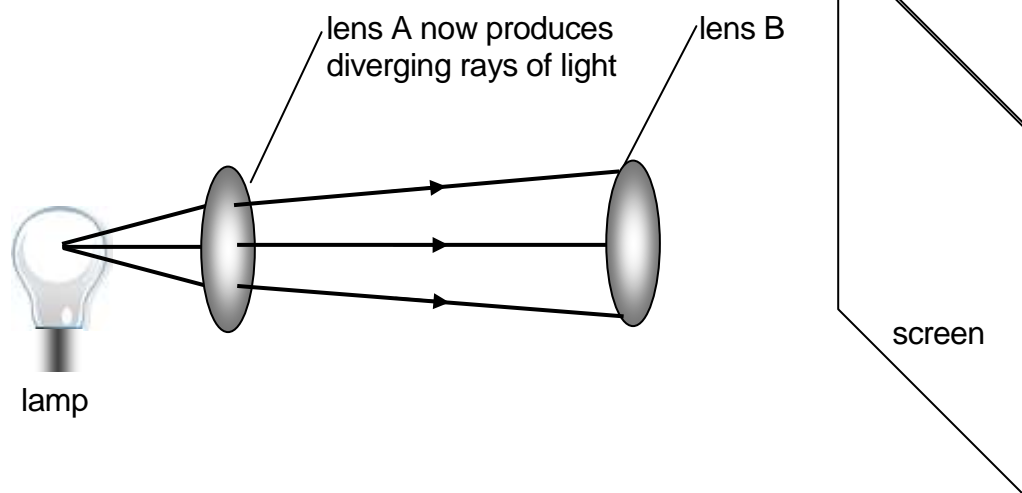

In which direction will the screen have to be moved to obtain a sharp image once again?

- (c) A pupil, who has poor vision, holds the lens in front of his eye and finds that it becomes sharper. What eye defect does the pupil suffer from?

Electromagnetic Spectrum

The electromagnetic spectrum

51. The electromagnetic spectrum is shown below.

radio and TV waves	microwaves	infrared radiation	visible light	ultraviolet radiation	X-rays	gamma radiation
--------------------	------------	--------------------	---------------	-----------------------	--------	-----------------

- (a) At what speed do waves in the electromagnetic spectrum travel at?
- (b) The Sun emits both visible light and X-rays. If they are emitted at the same time, which will reach the Earth first?
- (c) Which waves in the electromagnetic spectrum have:
- (i) the longest wavelength;
 - (ii) the highest frequency;
 - (iii) the shortest wavelength;
 - (iv) the lowest frequency?

52. The table below lists the frequency and wavelength of waves found in the electromagnetic spectrum. Copy the table and complete by calculating the missing values. Use the diagram on the next page to identify the part of the electromagnetic spectrum the wave belongs to.

	Wave frequency	Wavelength	Type of wave
(a)	3×10^{19} Hz		
(b)	4.3×10^{14} Hz		
(c)	3×10^{10} Hz		
(d)	7.5×10^{14} Hz		
(e)		3×10^{-8} m	
(f)		3×10^{-10} m	
(g)		3 m	
(h)		300 m	
(i)		1×10^{-5} m	

52 (continued)

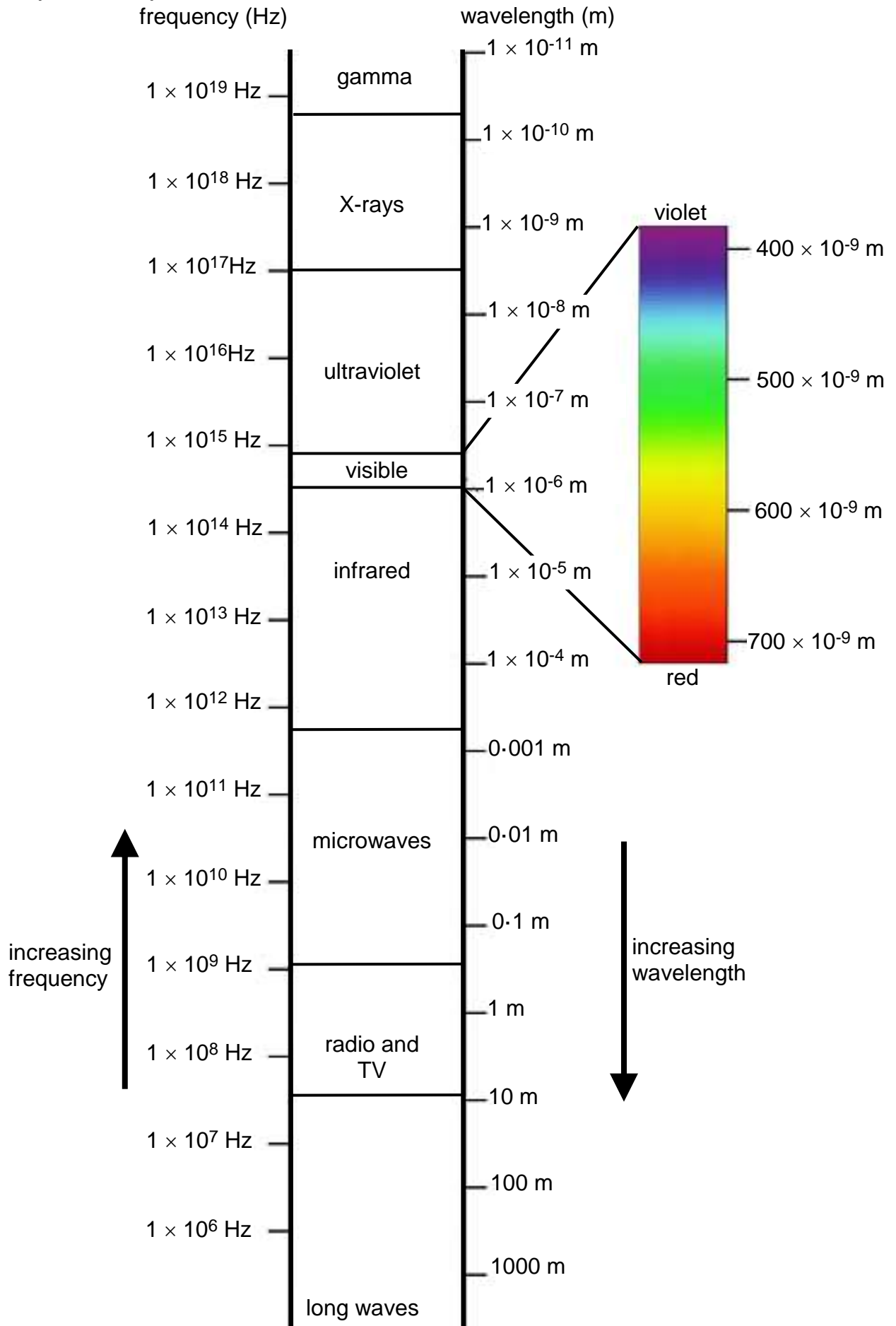

53. An ultraviolet lamp has a frequency of 1×10^{15} Hz. Calculate the wavelength of the light if it travels at 3×10^8 m s⁻¹.
54. A radio station broadcasts its radio signal at a frequency of 97.7 MHz.
- (a) What speed do the radio waves at?
 - (b) Calculate the wavelength of the waves.
 - (c) Calculate the time it takes the radio waves to travel 100 km?
55. An infrared source emits waves with a wavelength of 100 μ m. Calculate the frequency of these waves.
56. Gamma rays travel from the Sun at a speed of 3×10^8 m s⁻¹.
- (a) Calculate the time it takes for the rays to reach Earth if the Sun is 1.5×10^{11} m away.
 - (b) Calculate the frequency of the gamma rays if they have a wavelength of 3×10^{-12} m.
57. A mobile phone network uses microwaves with a frequency of 1800 MHz.
- (a) Calculate the wavelength of the microwaves.
 - (b) Calculate the time it takes for the waves to travel from the phone to a receiving mast 5 km away.

Applications of the electromagnetic spectrum

58. The table below gives types of electromagnetic radiation and possible source or detector Match the letters and numbers to correctly link them together.

Wave	Source or detector
(a) radio & TV	1 – sun bed
(b) microwave	2 – glow stick
(c) infrared	3 – Geiger counter
(d) visible light	4 – mobile phone
(e) ultraviolet	5 – radio one transmitter
(f) x ray	6 – toaster
(g) gamma ray	7 – photographic plate

59. Mobile phones use waves to transmit information.

- (a) Name the radiation adjacent to microwaves which have a longer wavelength than microwaves.
- (b) Name the radiation adjacent to microwaves which has a shorter wavelength than microwaves.
- (c) Part of the microwave spectrum can have applications other than communication. Name one of these.
- (d) Other waves in the electromagnetic spectrum are also used for communication in optical fibres. Name this radiation.

60. Infra red radiation is part of the electromagnetic spectrum.

- (a) Name a possible source of infrared radiation.
- (b) How can infrared radiation be detected?
- (c) Describe one use of infrared radiation.

61. The sign shown below is often displayed where there is the risk of exposure to high intensity ultraviolet light.



- (a) How can ultraviolet light be detected?
- (b) Explain why ultraviolet light can pose health risks for people who sunbathe.
- (c) Ultraviolet light can have uses. Describe one medical and one non-medical use for ultraviolet light.

62. X rays are used in hospitals to help with the diagnosis of a patient.



- (a) When the X-rays are taken, the staff are in a separate room from the patient. Why is this necessary?
- (b) Doctors avoid taking X-rays in young patients. Why would they do this?
- (c) The picture opposite shows an X-ray of a hand wearing a gold ring. Explain why the ring shows up so clearly.



63. A patient with a broken leg has an X-ray picture taken of their leg.

- (a) Explain why the image of the bone appears on the film.
- (b) The X-rays have a wavelength of 1×10^{-10} m. Calculate their frequency.
- (c) If the patient were a pregnant woman, the doctor would be reluctant to use X-rays to examine the break. Explain why.
- (d) What alternatives are available to a doctor if she did not want to use X-rays?

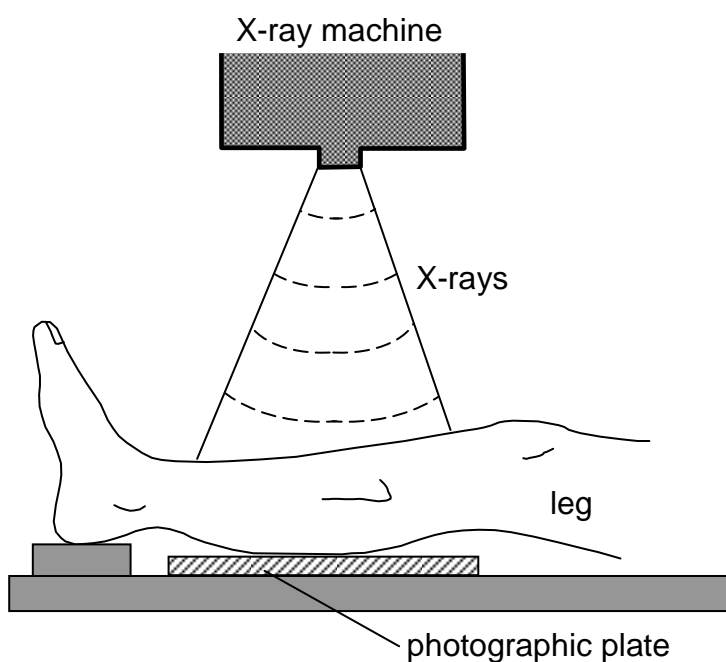

Frequency and energy

64. Copy and complete the passage which follows using the words below.

higher energy low longer shorter

Waves from the electromagnetic spectrum will transfer _____
from one place to another. The amount of energy the waves carry
depends upon the frequency or wavelength of the waves. The
_____ the frequency or _____ the wavelength, the more
energy they carry. Waves with a _____ wavelength and a
_____ frequency carry less energy.

65. Ultraviolet light can be grouped into uv A and uv B. Uv A has typical
wavelengths of 3×10^{-7} m whilst uv B has wavelengths of 4×10^{-7} m.

- (a) Show by calculation, which of the two types of uv has the highest frequency.
- (b) Which of the two types will cause most damage to our skin? Give reasons for your answer.

Extension Questions

66. A pupil uses a mobile phone to keep in touch with family and friends. It communicates with the reception mast using microwaves with a frequency of 900 MHz.

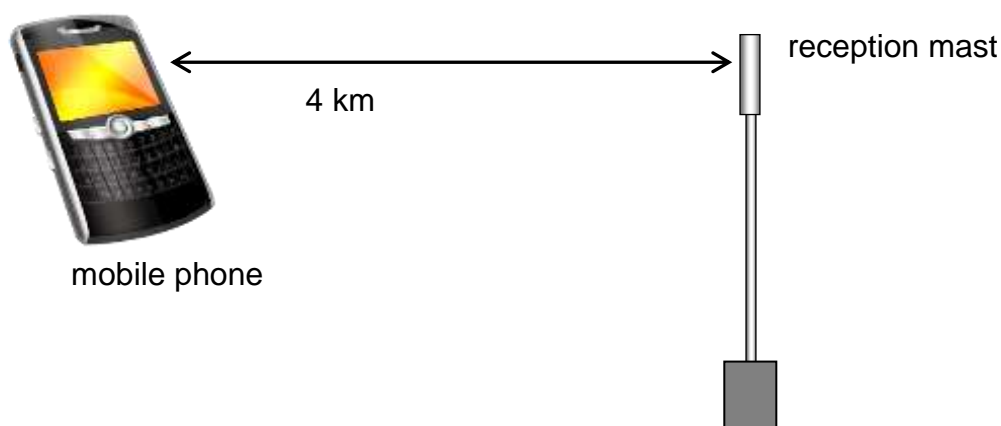

- (a) Calculate the wavelength of the microwaves being used.
- (b) Name the two waves on the electromagnetic spectrum with:
 - (i) a higher frequency;
 - (ii) a lower frequency.
- (c) Calculate the time it takes for the microwaves to travel between the phone and the reception mast.
- (d) Concern has been expressed about the dangers from microwave radiation of holding the phone close to the users head. Explain why there would be more concern about phones which use a higher frequency of microwave.
- (e) Microwaves are also used to communicate with satellites in orbit around the earth. It takes the microwave signal 0.12 s to travel from earth to the satellite. Calculate its distance away.

67. Read the passage below about waves then answer the questions which follow.

Electromagnetic radiation belongs to the electromagnetic spectrum (or EM spectrum). Unlike sound waves which need a medium to travel through, EM waves can travel through a vacuum. They also differ from sound waves as they are transverse waves rather than longitudinal waves.

The EM spectrum ranks radiation from waves with the longest wavelength and lowest frequency through to waves with the shortest wavelength and highest frequency. The shorter the wavelength, the more energy the waves can carry and so the more dangerous they are. This is why gamma rays and X-rays can cause considerable harm to our bodies yet radio and TV waves do not.

Radio waves have very long wavelengths which can be as long as a football pitch. They are created when electrons move within a conductor. Touching the terminals of a cell or battery together will create sparks which produce radio waves but unlike the radio stations we listen to, they are not all at the one frequency but over random frequencies. These would be picked up as static on a radio.

At higher frequencies on the EM spectrum are microwaves and infrared radiation. Infra red radiation absorbed by the body is felt as heat and all objects emit infrared radiation. The hotter the object the more infrared it emits. This is used in infrared photography which can be used to detect heat escaping from houses or areas of poor blood circulation in the body as these are cooler than surrounding tissue. Infrared radiation is just below the visible spectrum and some animals, such as snakes, can detect this to find prey in total darkness.

The visible spectrum is radiation that we can see with our eyes, red having the longest wavelength and violet the shortest. Ultraviolet light is found at frequencies higher than visible light. Ultraviolet light can cause damage to our skin if we are exposed to too much. Fortunately, the ozone layer in the atmosphere filters out most of the ultraviolet radiation reaching the Earth.

X-rays have a higher frequency than ultraviolet light and can penetrate through our bodies. This makes them useful for taking pictures of internal organs, broken bones etc. Some shoe shops in the 1950's had machines that used X-rays to produce an image of the bones in the foot so that the shop assistant could check if the shoe fitted properly! As soon as it was realised that people were being exposed to dangerous and unnecessary X-rays the use of the machines stopped.

Gamma rays have the highest frequency of all EM waves. They will destroy living cells but this property can be put to good use. Gamma rays are used to sterilise surgical instruments and carefully controlled burst of gamma radiation can be used to treat cancer tumours.

Now answer the questions below.

- (a) State two differences between sound waves and waves from the EM spectrum.
- (b) Give an example of an EM wave which can damage our bodies.
- (c) Explain why waves with a very short wavelength from the EM spectrum are more dangerous.
- (d) How are radio waves generated?
- (e) What would you hear on a radio if you connected the terminals of a battery together?
- (f) How do some animals use infrared radiation?
- (g) What prevents most of the ultraviolet radiation reaching the Earth's surface?
- (h) Why was the use of X-ray shoe fitting machines discontinued?
- (i) State two uses of gamma radiation.

Nuclear Radiation

Properties of Radiation

68. The diagram below represents an atom. Name the parts labelled (a), (b) and (c).

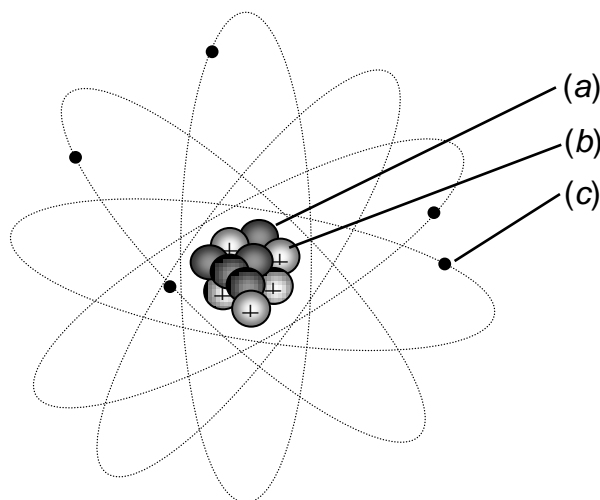

69. An atom is described as being neutral. What does this tell you about the numbers of electrons and protons in the atom?

70. Nuclear radiation is often described as '*ionising radiation*'. State what happens when nuclear radiation ionises an atom to produce ions.

71. Copy and complete the paragraph on nuclear radiation using the words given below.

air wave electron positive lead strongly
nucleus helium paper negative weakly

There are three different types of nuclear radiation – alpha, beta and gamma. Alpha radiation is a _____ nucleus and has a _____ charge. It is a _____ ionising radiation so will damage cells if it gets into the body. Fortunately, it is blocked by a thin sheet of _____ or a few centimetres of _____. Beta radiation is a fast moving _____ from the break up of a proton in an atom's _____. It has a _____ charge and requires 3 millimetres of aluminium to block it. The last type is gamma radiation which is not a particle but a _____ and part of the electromagnetic spectrum. Gamma requires 3 centimetres of _____ to block its path. Beta and gamma are _____ ionising radiations and do not ionise as strongly as alpha radiation.

72. The table below lists the three types of nuclear radiation and their properties. Copy and complete the table. Blocked by Ability to ionise

Radiation	What it is	Blocked by	Ability to ionise
alpha	2 protons and 2 neutrons	(a)	(b)
beta	(c)	about 3 mm of aluminium	(d)
(e)	a wave, part of the electromagnetic spectrum	(f)	weakly ionises

73. A smoke alarm uses a radioactive source to produce ionisation of the air in the detector. These ions cross between the electrodes and a small current flows. If smoke from a fire enters the alarm the amount of ionisation will decrease. This is detected by an electronic circuit and the alarm is activated.

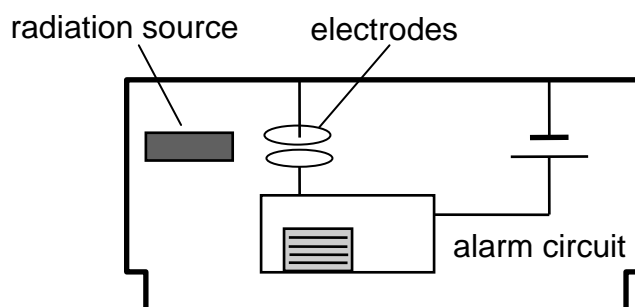

- (a) Explain what is meant by the term *ionisation*.
- (b) Why is an alpha producing radioactive source used rather than one which produces gamma or beta radiation?
74. What is the name given to the unit of radioactive decay which represents one decay per second?
75. In a sample of radioactive material there are 2×10^6 decays each second. Find the samples activity in Becquerels?
76. A sample of radioactive material has an activity of 5 kBq. How many decays will take place in 1 hour?
77. A radioactive isotope used in industry has an activity of 0.4 MBq. Calculate the number of decays which take place in 15 seconds?

78. (a) What is meant by the term '*background radiation*'?

(b) The table below lists a number of sources of background radiation. Copy and complete the table by putting a tick in the appropriate column to show whether the radiation is natural or man-made. The first is done for you.

Source	Natural	Man-made
Building materials		✓
Nuclear medicine		
Nuclear power stations		
Cosmic radiation		
Granite rock		
Radon gas		
Bananas		
Water		
Tobacco		
Smoke detectors		
Luminous watches		

Absorbed Dose and Equivalent Dose

79. (a) Write an equation linking absorbed dose, energy and mass.

(b) State the unit used to measure absorbed dose.

80. Calculate the missing values in the table below.

Absorbed Dose	Energy	Mass
(a)	5×10^{-6} J	1×10^{-2} kg
(b)	0.1 mJ	0.004 kg
50×10^{-6} Gy	(c)	0.5 kg
5×10^{-6} Gy	(d)	30 g
2×10^{-6} Gy	0.5 μ J	(e)
10 mGy	1×10^{-2} J	(f)

81. A mass of 0.4 kg absorbs 500 μ J of energy. Calculate the absorbed dose.

- 82.** A patient is undergoing radiotherapy treatment. The tumour they suffer from has a mass of 0.03 kg and it absorbs 0.5 J of energy. Calculate the absorbed dose?
- 83.** (a) State the formula which relates absorbed dose with equivalent dose.
 (b) State the unit used to measure equivalent dose.
- 84.** (a) The following table gives the weighting factor for certain types of radiation.

<i>Type of radiation</i>	<i>Weighting factor, w_R</i>
X-rays	1
gamma rays	1
beta particles	1
slow neutrons	5
fast neutrons	10
alpha particles	20

Why do different types of radiation have a different weighting factor.

- (b) Suggest a reason why alpha radiation has the highest weighting factor.

- 85.** Using the table above, find the absorbed equivalent dose for the following radiation exposures.

	<i>Absorbed dose</i>	<i>Type of radiation</i>
(a)	10 μ Gy	alpha particles
(b)	3 mGy	slow neutrons
(c)	50×10^{-6} Gy	fast neutrons
(d)	5×10^{-6} Gy	beta particles
(e)	2×10^{-6} Gy	X-rays
(f)	10 μ Gy	gamma rays

- 86.** A student breaks his arm during a PE lesson. The break is x-rayed and the absorbed dose he receives is $20 \mu\text{Gy}$. Calculate the equivalent dose he receives. (Use the weighting factors given in the table in question 78.)
- 87.** Calculate the equivalent dose if someone received an absorbed dose of 10 mGy from slow neutrons.
- 88.** A technician with a mass of 60 kg absorbs $200 \mu\text{J}$ of alpha radiation.
- (a) Calculate the absorbed dose she receives.
- (b) Calculate the equivalent dose she receives.
- 89.** A patient receives an absorbed dose of $10 \mu\text{Gy}$ from fast neutrons. Calculate the equivalent dose received.

Applications of nuclear radiation

- 90.** A manufacturer of tin foil uses an automatic thickness monitoring system which uses nuclear radiation. The pressure applied to the rollers will determine the thickness of the foil - the greater the pressure the thinner the foil. The radiation passing through the foil will vary with the thickness of the foil.

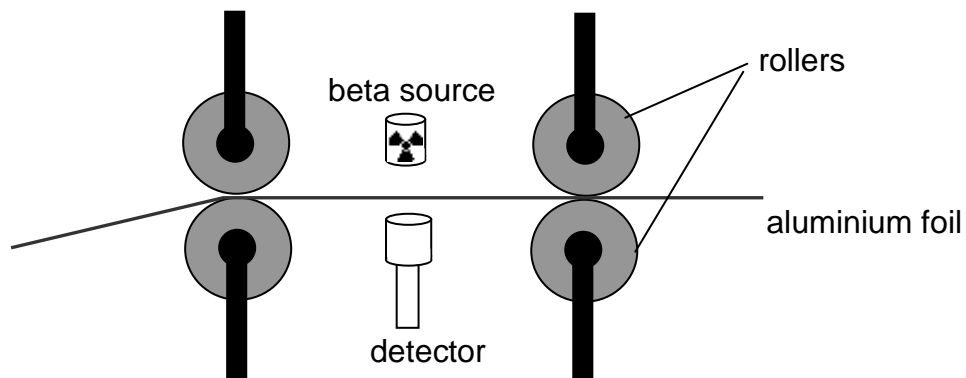

- (a) Why is beta radiation used rather than alpha or gamma radiation?
- (b) The count rate of the beta radiation decreases. What does this mean has happened to the thickness of the foil?
- (c) How will the roller pressure be altered if the foil is found to be too thin?

91. A doctor uses radioactive tracers to check the flow of blood through a patient's kidneys. One kidney is functioning normally and the other is blocked. A radioactive liquid which emits gamma radiation, is injected into the patient's bloodstream. The level of radiation emitted from the kidney increases then falls for a normal kidney but increases and remains steady for a blocked kidney.

The two graphs below show the radiation levels for each kidney.

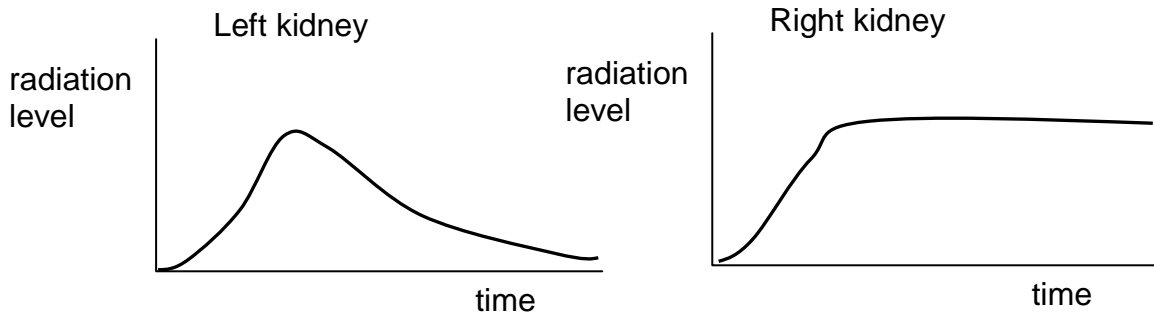

- (a) Give two reasons why a gamma emitter is used rather than an alpha emitter as the radioactive source.
- (b) Examine the graphs above and state which kidney is blocked.
- (c) Why will the level of radiation in the patient slowly decrease?
- (d) Iodine is naturally absorbed by the thyroid gland found in the neck. Radioactive iodine is injected into a patient and a gamma camera used to produce an image of their thyroid area. The image produced is shown below. The normal size and location of the thyroid is outlined.

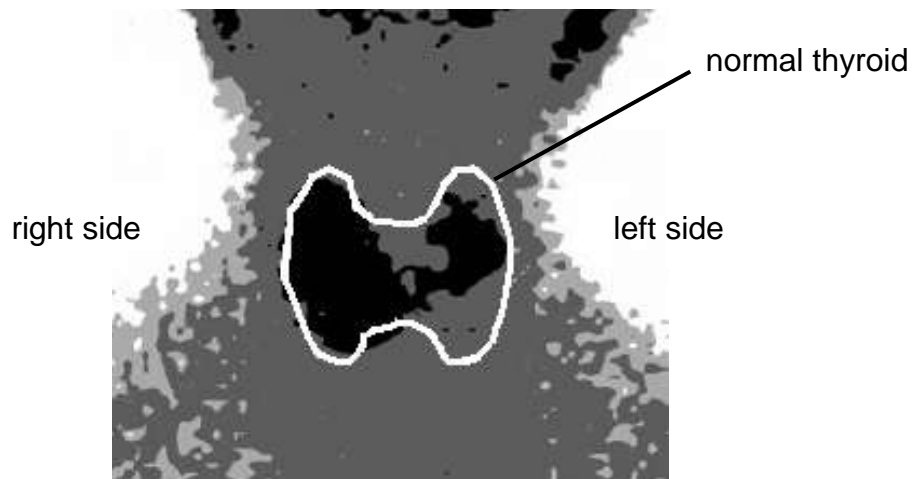

- (i) What information does the image from the gamma camera give about the absorption of the radioactive iodine?
- (ii) The radioactive iodine injected into the patient is prepared shortly before use. Why are larger batches not produced and stored.

92. A long section of underground water main has developed a leak. To find its location some radioactive liquid is added to the water flowing through the pipe and levels of radioactivity measured in the area above the pipe.

The diagram below shows the radiation levels in counts per minute.

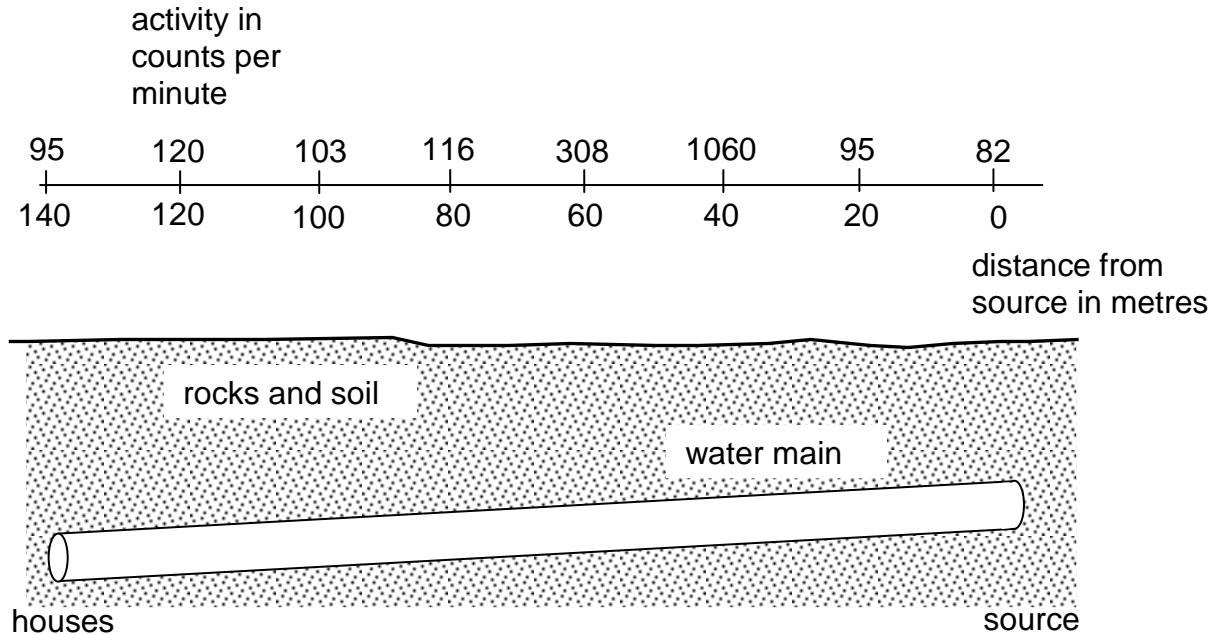

- (a) Why are the water supplies to houses supplied by the pipe disconnected during the test?
- (b) Suggest the distance from the source where the leak might be.
- (c) Why must a gamma emitting source be used for this test?

Half-life

93. State the meaning of the term '*half-life*'.

94. The activity of a radioactive sample decreases from 4000 counts per minute (c.p.m.) to 125 c.p.m. over a period of 40 minutes. Calculate the half-life of the source?

95. A radioactive source has a half-life of 8 hours. If the source has an initial activity of 32 000 Bq, find its activity after 2 days.

96. A radioactive sample has a half life of 2 days. Calculate the time it will take for its activity to drop to one sixteenth of its original value.

97. An experiment can be carried out to measure the half-life of a radioactive sample. The apparatus is shown below. The radioactive sample is placed in front of a Geiger-müller tube connected to a counter. The activity of the sample in counts per minute is measured every minute.

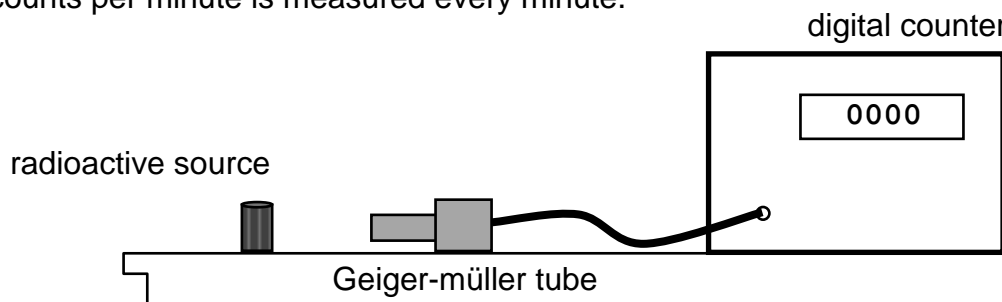

- Before the experiment, readings are taken for background radiation. What is background radiation?
- Will the readings for background radiation be added to or deducted from the experimental readings?
- A graph of the experimental results is shown below. Use the graph to calculate the half-life of the source.

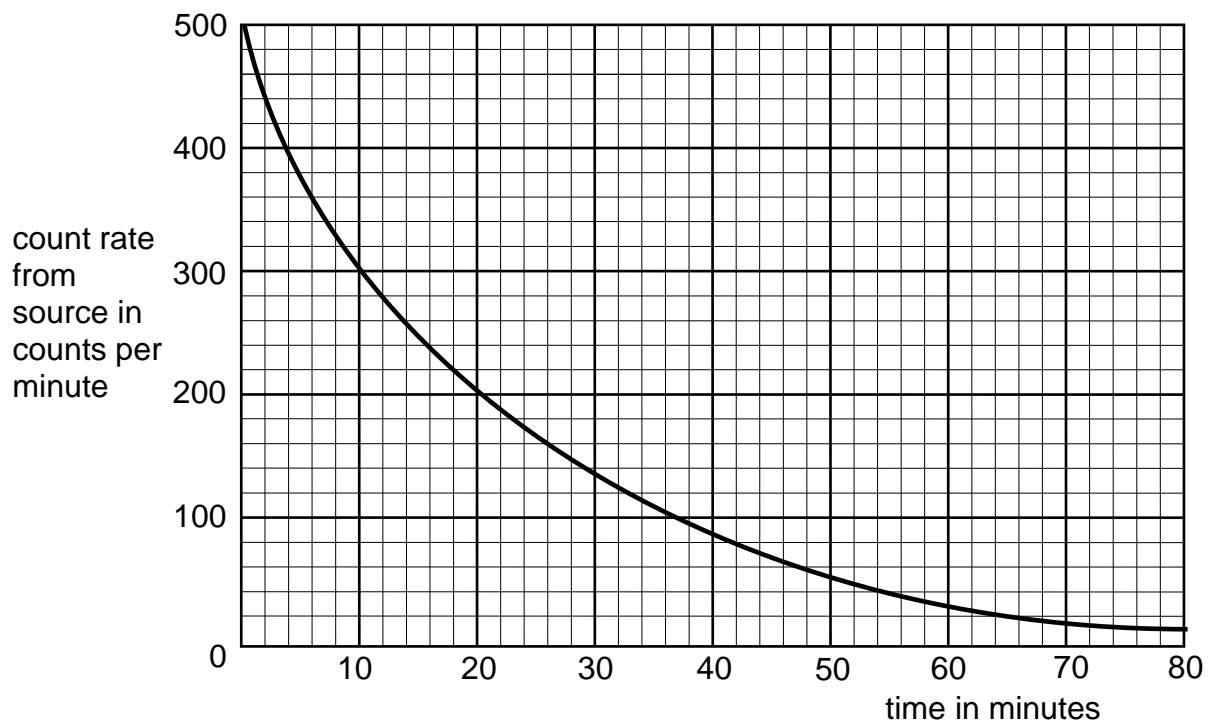

- A radioactive isotope has a half-life of 15 hours. 256 g of the isotope is placed in a sealed container. What mass of the isotope will remain radioactive after 60 hours?
- A radioactive isotope contains 640 million atoms of the isotope. How many isotope atoms will remain after 6 half-lives have passed.
- A radioactive rock with a half life of 8000 years has an activity of 20 MBq. What will be the activity after 40 000 years?

Nuclear power

101. Copy and complete the following paragraph using the words below.

uranium neutron heat split
smaller neutrons large

Nuclear fission takes place when a _____ collides with a _____ unstable nucleus of _____. This causes it to _____ into two _____ nuclei. At the same time it releases more _____ and a quantity of _____.

102. Copy and complete the following paragraph using the words below.

heat Sun small larger

Nuclear fusion takes place when two _____ nuclei collide and join together to create a _____ nucleus. This also causes _____ energy to be released. This is the same atomic reaction that provides the energy for the _____.

103. Look at the block diagram of a nuclear power station below.

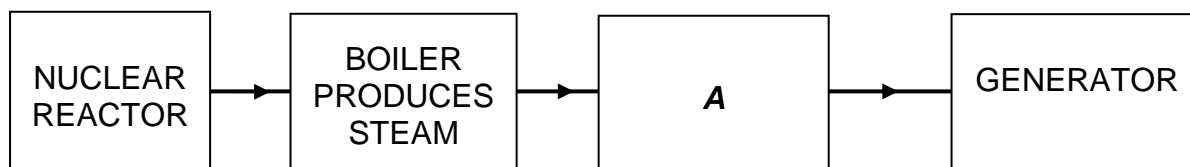

- (a) Name the part labelled **A**.
- (b) Heat is produced by the nuclear reaction. What happens to this heat?
- (c) Describe the purpose of the generator.
- (d) What energy conversion takes place in the nuclear reactor?

104. (a) Explain the difference between a nuclear fission reaction and a nuclear fusion reaction.
- (b) State which of these two reactions, fission or fusion, is used in a nuclear power station.

105. A chain reaction takes place in the core of a nuclear reactor. Explain what is meant by a chain reaction

106. The diagram below represents the sequence of events in a nuclear fission reaction. Describe what is happening at A, B and C.

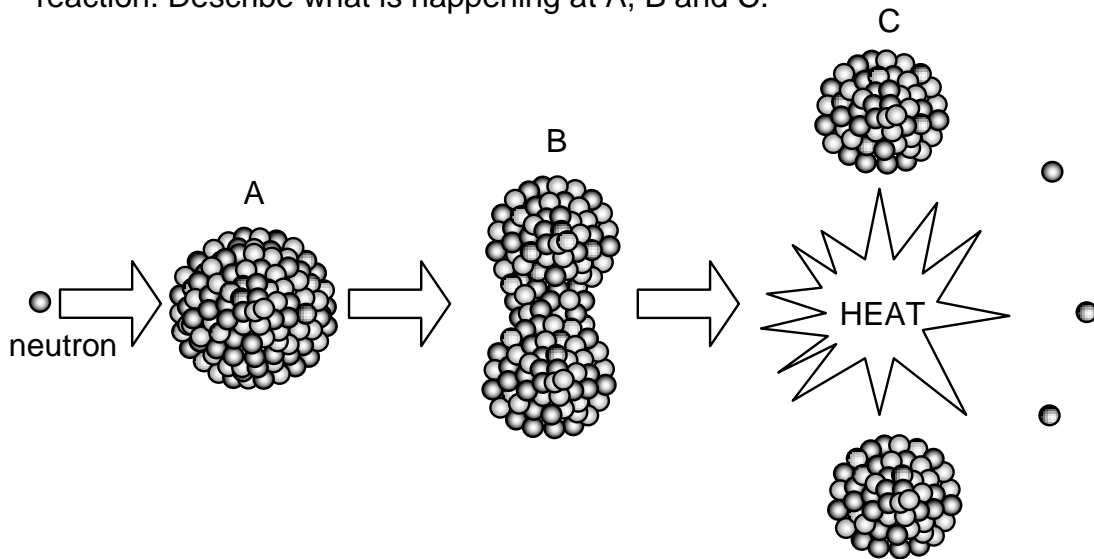

107 Listed below are some statements relating to the generating of electricity using nuclear reactors. For each statement, say whether you think it is true or false.

1. The vast majority of radiation we are exposed to comes from space and the ground beneath our feet.
2. Nuclear power stations will run out of fuel in just a few years.
3. Waste from nuclear reactors must be stored underground for a long time until the radiation emitted decreases.
4. Nuclear reactors use the process of nuclear fission to produce heat.
5. Nuclear reactors can be built very quickly.
6. Nuclear reactors produce a large amount of sulphur dioxide which produces acid rain.
7. Most of the radiation we are exposed to comes from nuclear power stations.
8. Nuclear reactors cannot generate enough electricity to meet high power demands like industry.
9. Nuclear reactors produce large volumes of greenhouse gases.
10. All the nuclear reactors in the world are the same type as the one that exploded in Chernobyl.



Extension Questions

108 Four samples of radioactive material are isolated and tested for their penetrating properties.

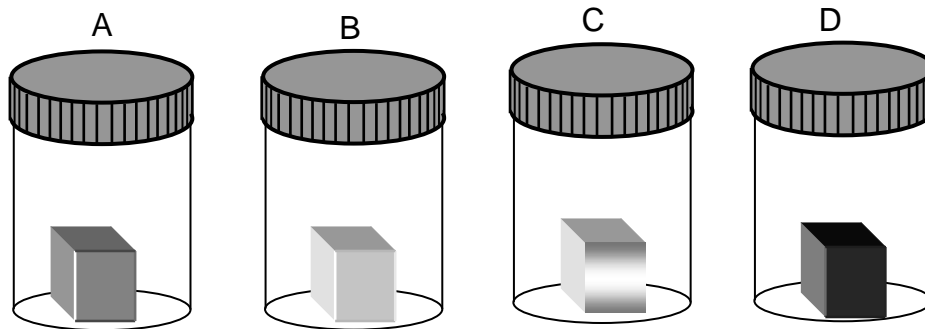

The following information is obtained after conducting experiments on each of the samples.

Sample	Radiation blocked by		
	Sheet of paper	3 millimetres of aluminium	3 centimetres of lead
A	No	Partial	Yes
B	Yes	Yes	Yes
C	No	No	Yes
D	No	Yes	Yes

- (a) Which sample or samples emitted beta radiation only?
- (b) Which sample or samples emitted alpha radiation only?
- (c) Which sample or samples emitted gamma radiation only?
- (d) Which sample or samples emitted more than one kind of radiation?
- (e) (i) 128 000 nuclei decay in a radioactive sample every 32 seconds. Calculate the activity of the sample.
- (ii) The sample has a half-life of 3 hours. Calculate the activity of the sample after 12 hours.

- 109** An experiment is set up to measure the half-life of a radioactive source. The source is placed in a drip tray and a Geiger-müller tube placed above it. This is connected to a digital counter.

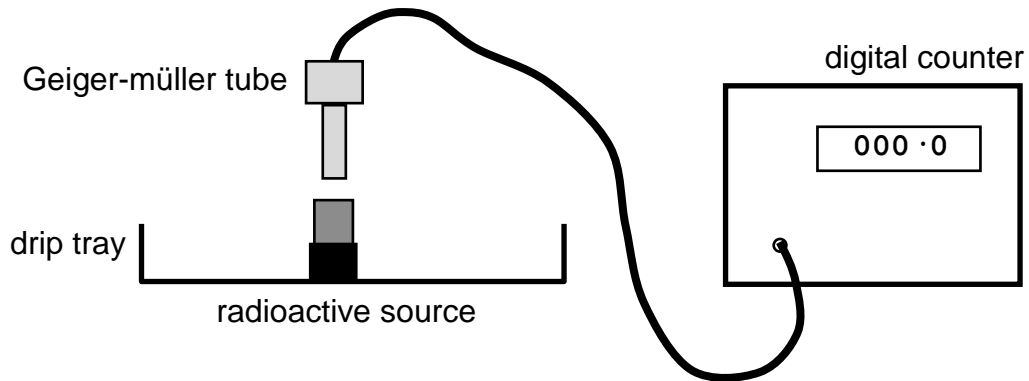

- (a) The results are corrected for background radiation. Name three sources of background radiation.
- (b) The graph below is produced from the results of the experiment. Find the half-life of the source.

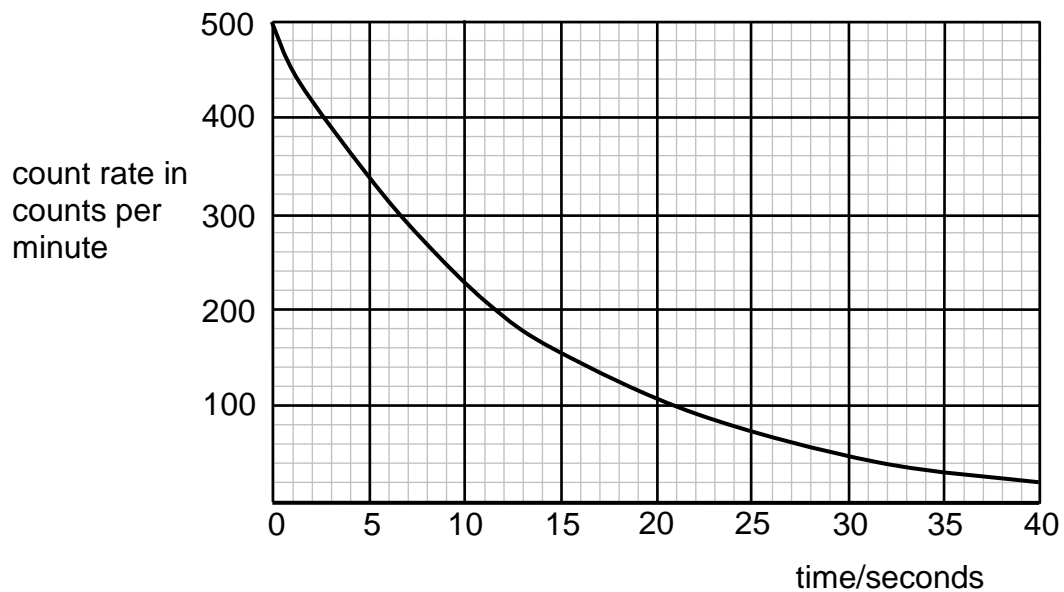

- (c) A drip tray is placed under the source as a safety precaution. Explain why this is done.
- (d) In the experiment above the source has a relatively short half-life. Waste from nuclear reactors can have a very long half-life. How is this waste dealt with?

110. An experiment is carried out to find the half-life of a radioactive source. The graph produced from the results of this experiment are shown below.

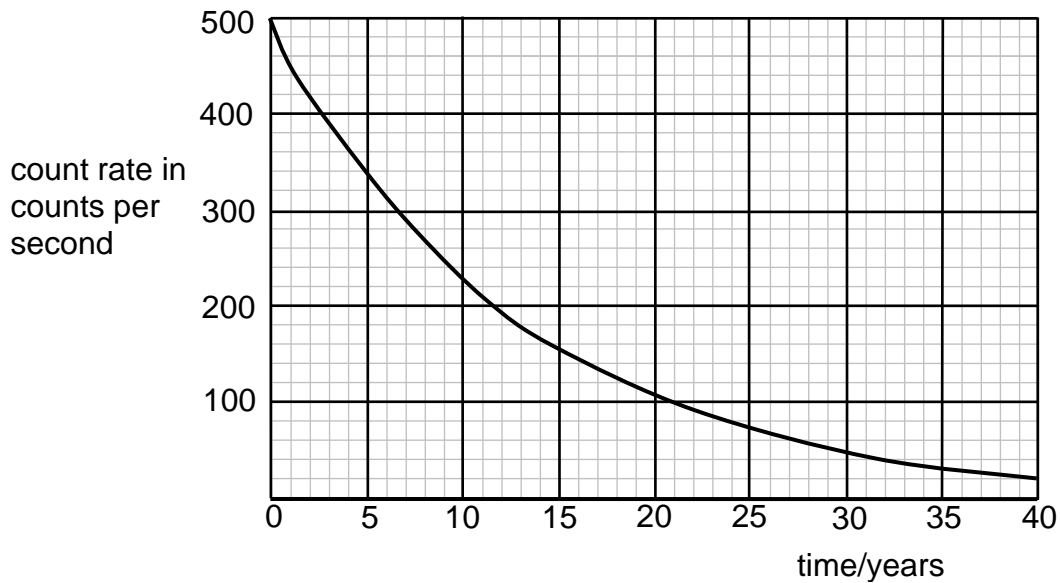

- (a) State the meaning of the term “*half-life*”.
- (b) Find the half-life of this radiation sample from the graph above.
- (c) Geiger-Müller tubes can be used to measure the amount of radiation produced by a source. Radiation entering the tube ionises the gas inside the tube. Explain what is meant by the term *ionisation*.
- (d) A radioactive form of carbon is absorbed by all living things. Once the animal or plant dies, the level of radioactivity slowly falls. The half-life of the carbon is 6000 years.

Some ancient human remains are tested and the count rate is found to be 8000 counts per minute. Calculate the age of the bones if the original count rate would have been 32 000 counts per minute.

